

User's Guide

PROTO2

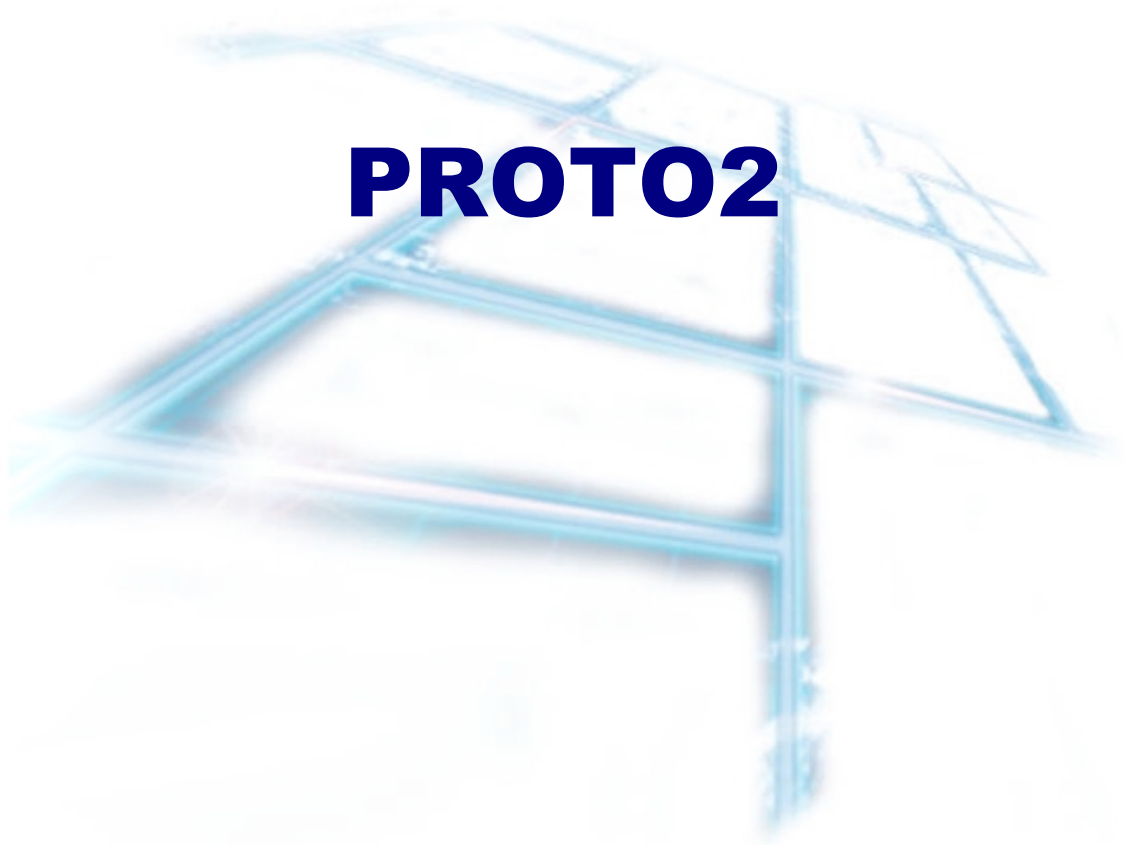

Copyright © QUANCOM Informationssysteme GmbH

All specification in this manual was arranged after careful check, and it is not considered as any warranty of product properties. QUANCOM shall not be responsible for any errors or omissions contained in this user's manual, and reserves the right to make changes without notice. Passing on and duplication of this manual and the utilisation of its contents as well as the software belonging to the product are permitted only with written permission by QUANCOM.

Table of contents

| | | |
|----------|--|-----------|
| 1 | Overview..... | 5 |
| 1.1 | Introduction | 5 |
| 1.2 | Our experience is your profit..... | 5 |
| 1.3 | Customer Communication..... | 5 |
| 1.4 | Changes in this manual and software updates | 6 |
| 1.5 | Scope of supply..... | 6 |
| 2 | Installation procedures | 7 |
| 2.1 | System requirements | 7 |
| 2.2 | Safety precautions | 7 |
| 2.3 | Installing the board..... | 8 |
| 3 | Technical hardware description | 9 |
| 3.1 | Cardinformation | 9 |
| 3.2 | Technical data..... | 9 |
| 3.3 | Board Overview PROTO 2..... | 10 |
| 3.3.1 | The 37-pin D-Sub-Socket and the 40-pin connector pin assignment..... | 11 |
| 3.3.2 | Connector's Pin assignment | 12 |
| 4 | The PROTO2 GAL-Equations..... | 13 |
| 4.1 | EQUATIONS..... | 13 |
| 5 | Direct I/O programming..... | 14 |
| 5.1 | Software..... | 14 |
| 5.1.1 | Which software to use ?..... | 14 |
| 6 | Softwareprogramming with the QLIB..... | 15 |
| 6.1 | QLIB (QUANCOM Driver Library) | 15 |
| 6.2 | Installation and general programming with the QLIB | 16 |
| 6.2.1 | Installing the QLIB and drivers for your QUANCOM board (Windows Me/98/95)..... | 17 |

| | | |
|----------|---|-----------|
| 6.2.2 | Installing the QLIB and drivers for your QUANCOM board (Windows XP/2000/NT) | 18 |
| 7 | QLIB Commands..... | 19 |
| 7.1 | General functions | 19 |
| 7.2 | Special functions | 20 |
| 8 | Annex..... | 22 |
| 8.1 | Frequently asked questions (FAQ) | 22 |
| 8.1.1 | General informations..... | 22 |
| 8.1.2 | What kind of problems may occur if the board is running under DOS | 23 |
| 8.1.3 | Problems with boards running under Windows 98/95 and Windows XP/2000/NT | 23 |
| 8.2 | Customer Communication and Help | 26 |
| 8.3 | Technical support form..... | 29 |
| 8.4 | Hardware and software configuration form | 30 |
| 8.5 | Documentation comment form | 31 |

1 Overview

1.1 Introduction

Congratulations! You've bought a QUANCOM high quality measurement and automation board, which shows the newest update of technology and whose attributes and functions are able to compete with every other instrument and even beats them. The following special attributes are included:

Features of the board

- Easy programming
- Various sample applications in different programming languages
- Driver support by Windows XP, 2000, NT and Me/98/95 with the **QLIB (QUANCOM Driver Library)**

1.2 Our experience is your profit

We from QUANCOM are specialists for the development of hard- and software. QUANCOM has grown to become one of the leading suppliers of measuring and automation technology to industry. At its design centres QUANCOM has developed an impressive range of products.

1.3 Customer Communication

QUANCOM wants to receive your comments on our products and manuals. We are interested in the applications you develop with our products, and we want to help if you have problems with them. To make it easy for you to contact us, this manual contains comment and configuration forms for you to complete. These forms are in chapter 8.2 "*Customer Communication and Help*" at the end of this manual.

1.4 Changes in this manual and software updates

QUANCOM - products are marked out by their constant further development. You can watch all the actual information of the changes in the README-file on the installation disk or CD. You can always get more information and free software updates on our internet website.

(WWW.QUANCOM.DE)

1.5 Scope of supply

- Measuring and automation board
- User's manual
- QUANCOM CD

If a component is missing please contact your dealer. QUANCOM reserves the right to change the extent of delivery without a preliminary announcement.

2 Installation procedures



2.1 System requirements

- Personal computer: The QUANCOM boards are assigned to operate in IBM-AT compatible computers with 80X86 or compatible. (i.e. 80386 / 80486 / Pentium)
- Bus: Your computer must have the corresponding bus. (PCI / ISA)

You can find more information in chapter 2.3, “ Technical Hardware Description”.

2.2 Safety precautions

For the sake of your security and of a safe function of your new QUANCOM board mind the following advice:

- Before opening the computer please unplug it.
- Computer motherboards and components contain very delicate integrated circuit (IC) chips. To protect them against damage from static electricity, you must follow some precautions whenever you work on your computer. Use a grounded wrist strap before handling computer components. If you don't have one, touch both of your hands to a safely grounded object or to a metal object, such as the power supply case.
- Hold components by the edges and try not to touch the integrated circuit chips, leads or circuitry.
- Place components on a grounded anti-static pad or on the bag that came with the component whenever the components are separated from the system.

! ATTENTION ! Modifications, made at the device without express permission of QUANCOM, lead to the loss

2.3 Installing the board

CAUTION:

1. Always turn the system power off and remove the power cord from the wall before installing or removing any device.
2. Always observe static electricity precautions.
See „*Safety precautions*“ in chapter 2.2

1. Switch off the computer and the connected devices and unplug them.

Warning: Static electricity can destroy your computer and the board!

Discharge yourself as described in chapter 3.2 “*Safety precautions*“.

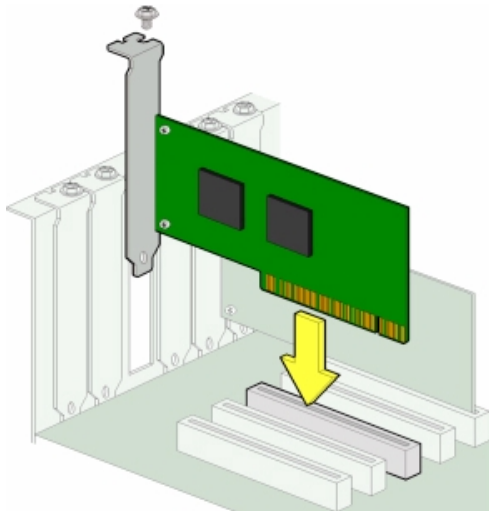

2. To open your PC you have to detach the four safety screws on the back of the case with a screw driver. Then you can pull the cover forwards. If necessary you must remove impeding cables.

3. The slots are positioned at the back side of your computer. The back wall of unused slots is covered by a small metal plates. Search for a free slot, detach its holding screw and remove the small metal plate belonging to it.

4. Position the extension card into a free slot. Pay attention that the card is set firmly in the slot.

5. Fasten the board with the screw of the small metal plate on the back wall.

6. Close the cover of your computer. Cables, that you detached during the installation, should now be reconnected.

7. Connect the cable of the board into the slot belonging to it.

3 Technical hardware description

3.1 Card information

This card was developed for testing and developing PC slot cards for the PCI-bus or circuit parts. The user can build relatively extensive circuits on a large proto typing field. Possible is, for example, the operation of a fast 8-Bit A/D converter, or measuring the temperature in the PC in conjunction with an A/D converter. It is possible to exchange data via three more 8-Bit ports, if a 8255 is available to the user. Of course optocouplers or Relays can also be controlled. Complex digital circuits can be implemented through the use of more PLD's or FPGA's. The decoding of the PCI-busses takes place with the Quancom PCI-decoder chip and makes diverse signals, i.e. an 8 Bit-data bus, IOWR, IORD and further bus signales available. An additional GAL generates further chip-selects. You can tap the above signals on a connector. For signalling an 8 Bit port, a LED-bar is on the card. You can undertake pre-adjustments on the data bus with a DIL-switch. It is possible for the user to send data out via a 37-pin D-Sub socket, resp. a 40-pin connector.

3.2 Technical data

- **General I/O**
 - data bus: D0...D7
 - address bus: A0...A4
 - control bus: IORD, IORW, RST, INT, CLKPCI
 - OSCILL
 - Freeing signals: for max. 32 I/O addresses
 - CS2...7, CSALL
 - Supply voltage: +5V, +12V, -12V
- **Connector** 37-pin D-Sub, 40-pin
- **I/O Address** PCI
- **Temperature range** 0..70°C
- **Dimensions** 168 x 96mm

3.3 Board Overview PROTO 2

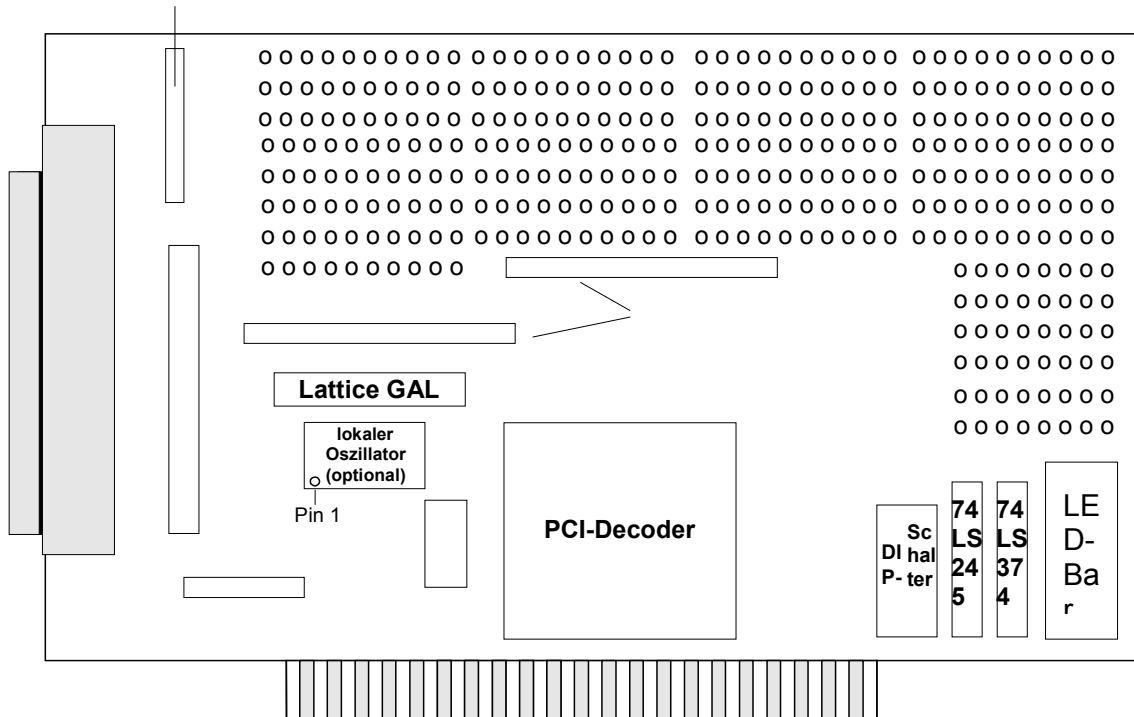

Note: On the bottom left connector there are 3,3 V available, but the card is solely designated for a 5V operation.

The Oscillator is not equipped. The use, resp. the choice of frequency is left up to you. Please notice the markings. The installation may only be done as shown above in the card overview, else the oscillator could be destroyed.

3.3.1 The 37-pin D-Sub-Socket and the 40-pin connector pin assignment

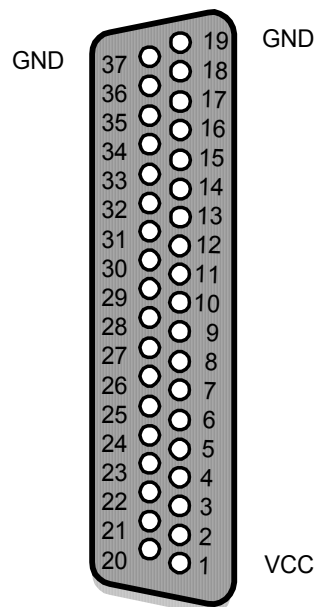

All other conductions can be used at your disposal and are connected with the 40-pin connector !

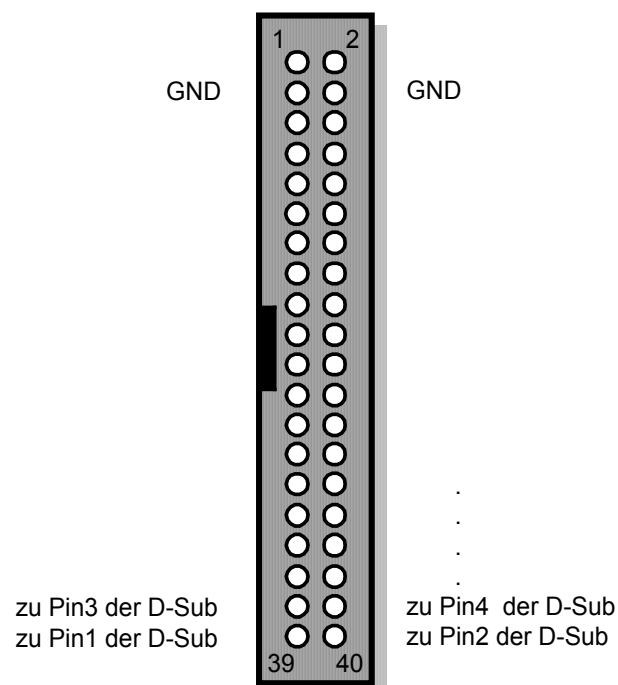

3.3.2 Connector's Pin assignment

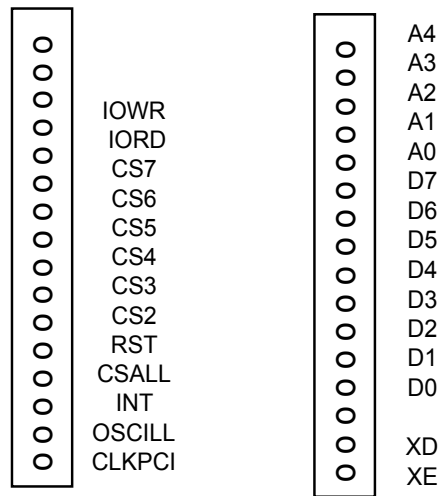

3.3.2.1 Signal descriptions

| | | |
|--------|-----------------|--|
| IOWR | out, active low | Write on a I/O-Address |
| IORD | out, active low | read from a desired I/O-Address |
| CS2..7 | out, active low | access a certain Port-Area CS2..Port+04..07 CS3..Port+10..1F CS4..Port+08 CS5..Port+09 CS6..Port+0A CS7..Port+0B |
| RST | out, active low | reset from CP4 |
| CSALL | out, active low | Chip select shows (when low), that data and address lines are valid |
| INT | out I | PCI-Bus Interrupt signal |
| OSCILL | out | local oscillator tact signal |
| CLKPCI | out | PCI-Bus tact |
| A0..A4 | out | address lines A0...A4 |
| D0..D7 | in/out | 8 Bit Data bus |
| CS0 | intern | CS0..Port+00..03 write CS1..Port+00..03 read |
| XD | out/intern | |
| XE | out/intern | |

4 The PROTO2 GAL-Equations

| | | | | | | | | | |
|----|-----|-----|-----|-----|------|------|-------|-----|-----|
| 1 | 2 | 3 | 4 | 5 | 6 | 7 | 8 | 9 | 10 |
| A0 | A1 | A2 | A3 | A4 | IORD | IOWR | CSALL | NC | GND |
| 11 | 12 | 13 | 14 | 15 | 16 | 17 | 18 | 19 | 20 |
| NC | CS0 | CS1 | CS2 | CS3 | CS4 | CS5 | CS6 | CS7 | VCC |

4.1 EQUATIONS

```

/CS0.TRST = VCC
/CS1.TRST = VCC
/CS2.TRST = VCC
/CS3.TRST = VCC
/CS4.TRST = VCC
/CS5.TRST = VCC
/CS6.TRST = VCC
/CS7.TRST = VCC

```

```

/CS0= /CSALL*(/IOWR) * /A4 * /A3 * /A2 ;00-03 write
/CS1= /CSALL*(/IORD ) * /A4 * /A3 * /A2 ;00-03 read
/CS2= /CSALL*(/IORD+/IOWR) * /A4 * /A3 * A2 04-07 read/write
/CS3= /CSALL*(/IORD+/IOWR) * A4 ;10-1f read/write
/CS4= /CSALL*(/IORD+/IOWR) * /A4 * A3 * /A2 * /A1 * /A0 ;08 read/write
/CS5= VCC ;can be used at your disposal
/CS6= VCC ; can be used at your disposal
/CS7= VCC ; can be used at your disposal

```

5 Direct I/O programming

5.1 Software

5.1.1 Which software to use ?

The software to be use depends on the operating system being used or your application. To access the board, following possibilities exist:

- **Method 1:** Direct I/O (access the hardware registers directly, all operating systems)
- **Method 2:** High-Level programming (access the board with the QLIB)
- **Method 3:** Install the QLIB for use with existing software

If you use **Method 1 and 2** you need the sources for the application. You are responsible for adding the programming statements in the application. For using these methods, knowledge in programming is necessary. See chapter 4 for a complete discussion of the hardware registers. Chapter 6.2 shows you how to use and install the QLIB.

Method 3 allows you to get the QUANCOM board running with existing software, i.e. the Sitekiosk browser software. The only thing you have to do in this case, is to install the QLIB Driver Library from the Installation CD. For details on installing the QLIB see chapter 6.2.

6 Softwareprogramming with the QLIB

6.1 QLIB (QUANCOM Driver Library)

The **QLIB**, which stands for **QUANCOM Driver LIBrary**, was developed with the target to allow the simple programming of all our data acquisition products under various operating systems. So it is easy to write an application that runs under the operating systems Windows Me/98/95 and Windows XP/2000/NT4.0. This driver interface is not limited to PC boards or other I/O adapters but is also targeted towards supporting the next product generations currently being developed. The used functions and parameters are the same for all operating systems.

Supported operating systems:

- Microsoft Windows XP/2000/NT4.x
- Microsoft Windows ME/98/95

Supported compilers:

C / C++

- Borland C++ 3.1, 4.x, 5.x, 6.x
- Microsoft® Visual C++ 1.x, 2.x, 4.x, 5.x, 6.x

Pascal

- Borland Turbo Pascal

Delphi

- Borland Delphi

Basic

- Microsoft® Visual Basic 3.x, 4.x, 5.x; 6.x

Graphical Programming Language

- HP VEE von Hewlett-Packard
- LabView® von National Instruments

6.2 Installation and general programming with the QLIB

For further information about the installation process and the general programming with the QLIB (i.e. setting up the system, linking libraries, adding header files, etc.) please see the „QLIB“ manual or the windows help file (qlib.hlp) which is included on the installation CD.

The following chapters describe the installation of the drivers depending on the operating system (Windows 95 / 98 or Windows XP / 2000 / NT) and bus type (PCI, ISA). The installation procedure differs for every operating system and bus type.

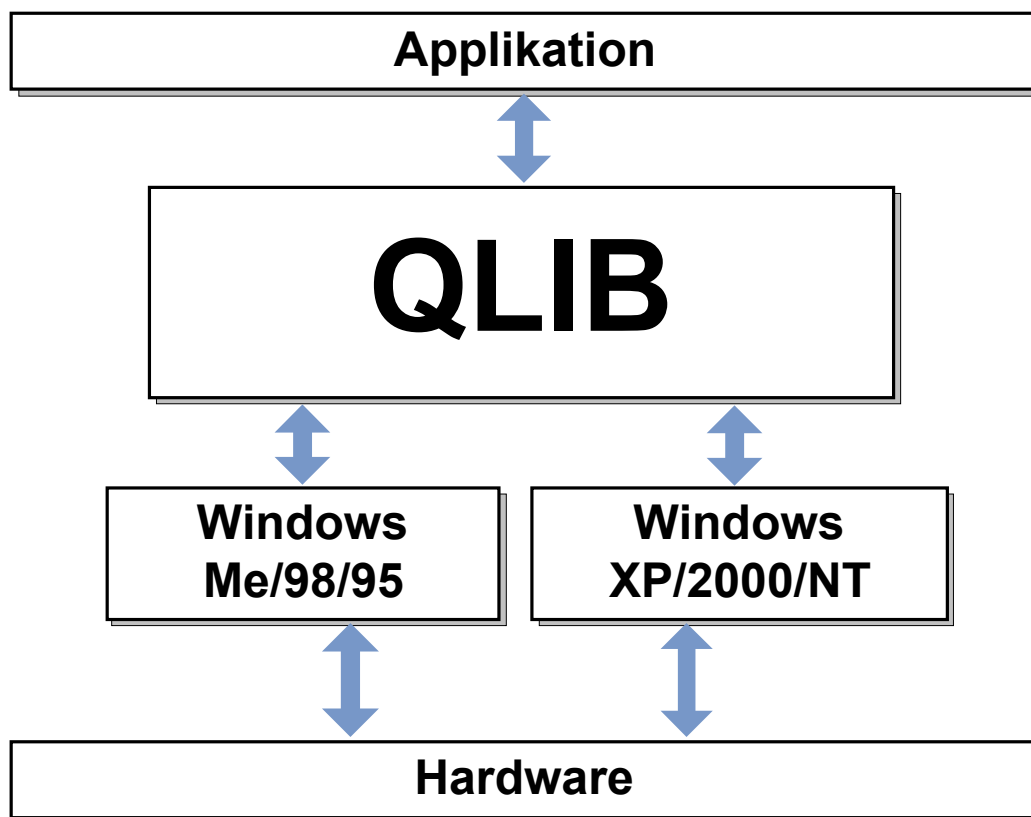

6.2.1 Installing the QLIB and drivers for your QUANCOM board (Windows Me/98/95)

If you have downloaded the QLIB Software from our website please read the note below before installing any drivers.

Step1: Driver installation for PCI boards:

After you installed the QUANCOM PCI board in your system the board will be recognised automatically by Windows 95/98 during system restart. If you are restarting the system the system detects the new board and opens a dialog box „New hardware detected“. Press the button „Have disk“ and insert the **QLIB installation Disk 1** in drive „A“. To properly recognise the board you have to select the file **A:\WIN95\QUANCOM.INF** or **A:\WIN98\QUANCOM.INF** depending of the operating system you are using. After the file was loaded a list of the PCI boards is shown. Please select the right board from the list.

Step 2: Software installation for PCI boards:

Put the **QLIB installation Disk 1** in drive A: and click on **Start | Run**. Select the program **a:\setup.exe** and click on **OK** to continue. The installation program will be started now and will guide you through the rest of the installation process. **SETUP.EXE** will install the QLIB software library.

NOTE: This section tells you what to do if you downloaded the QLIB from the web (QUANCOM Library)
If you have downloaded the QLIB from our website „<http://www.quancom.de/QLIBENG>“ you received a program like „qlib32_v160.exe“. Create a directory „i.e. **C:\QLIBINST**“ on you harddrive. Copy the program to this directory. Change on the DOS commandline to this directory and run the program. „**qlib32_v160.exe**“. This will extract the archived files to your harddisk. If you are asked in the following steps to select the i.e. **A:\WIN95\QUANCOM.INF** or **A:\SETUP.EXE** don't switch to drive „A:“ but rather to „i.e. **C:\QLIBINST\DISK1\WIN95\QUANCOM.INF**“ or „**C:\QLIBINST\DISK1\SETUP.EXE**“.

6.2.2 Installing the QLIB and drivers for your QUANCOM board (Windows XP/2000/NT)

If you have downloaded the QLIB Software from our website please read the note below before installing any drivers.

NOTE: Windows 2000 Plug & Play

If Windows 2000 shows the dialog box „New hardware found“ on system start press the button „CANCEL“. Don't use „Have disk“ button. The required drivers will be installed with the QLIB in Step 1.

Step1: Software and Driver installation for PCI boards:

Put the QLIB installation Disk 1 in drive A: and click on **Start | Run**. Select the program **a:\setup.exe** and click on **OK** to continue. The installation program will be started now and will guide you through the rest of the installation process. SET-UP.EXE will install the QLIB and the needed drivers.

NOTE: This section tells you what to do if you downloaded the QLIB from the web (QUANCOM Library)

If you have downloaded the QLIB from our website „<http://www.quancom.de/QLIBENG>“ you received a program like „qlib32_v160.exe“. Create a directory „i.e. **C:\QLIBINST**“ on you harddrive. Copy the program to this directory. Change on the DOS commandline to this directory and run the program. „**qlib32_v160.exe**“. This will extract the archived files to your harddisk. If you are asked in the following steps to select the i.e. **A:\WIN95\QUANCOM.INF** or **A:\SETUP.EXE** don't switch to drive „A:“ but rather to „i.e. **C:\QLIBINST\DISK1\WIN95\QUANCOM.INF**“ or „**C:\QLIBINST\DISK1\SETUP.EXE**“.

7 QLIB Commands

Make sure that the QLIB (QUANCOM Driver Library) is properly installed. For programming the UNITIMER board you need at minimum the QLIB release v1.70. For further information about the installation and how to include the necessary files in your application see the „QLIB“ documentation. This chapter describes the special commands that are required to use the UNITIMER board with the QLIB. These samples assume that the board is installed and properly set-up for use with the QLIB (QUANCOM Driver Library).

7.1 General functions

QAPIExtOpenCard

```
ULONG QAPIExtOpenCard ( ULONG cardid, ULONG devnum );
```

Use the function QAPIExtOpenCard to open a board and retrieve the board handle

QAPIExtCloseCard

```
void QAPIExtCloseCard( ULONG cardhandle );
```

With the function QAPIExtCloseCard the board is closed

QAPINumOfCards

```
ULONG QAPINumOfCards (void);
```

With the function QAPINumOfCards it is possible to ask , which used cards are supported by the QLIB

QAPIExtNumOfCards

```
ULONG QAPIExtNumOfCards (void);
```

With the function QAPIExtNumOfCards it is possible to ask , which used cards are supported by the QLIB

7.2 Special functions

QAPIGetCardInfo

```
LPCARDDATAS QAPIGetCardInfo ( ULONG cardid );
```

With the function QAPIGetCardInfo it is possible to get some information about the card

QAPIGetCardInfoEx

```
ULONG QAPIGetCardInfoEx( ULONG cardid LPCARDDATAS lpcd );
```

With the function QAPIGetCardInfoEx it is possible to get some information about the card. These will be written into the applications memory

QAPISpecial

```
ULONG QAPISpecial ( ULONG cardid ULONG jobcode ULONG para1 ULONG para2 );
```

With this function QAPISpecial it is possible to run card specific functions

QAPIExtSpecial

```
ULONG QAPIExtSpecial ( ULONG cardhandle ULONG jobcode ULONG para1 ULONG para2 );
```

With this function QAPIExtSpecial it is possible to run card specific functions

QAPIExtGetCardInfo

```
LPCARDDATAS QAPIExtGetCardInfo( ULONG cardid );
```

With the function QAPIExtGetCardInfo it is possible to get some information about the card

QAPIExtGetCardInfoEx

```
ULONG QAPIExtGetCardInfoEx( ULONG cardid LPCARDDATAS lpcd );
```

With the function QAPIExtGetCardInfoEx it is possible to get some information about the card. These will be written into the applications memory

QAPIExtReleaseCardInfo

```
void QAPIExtReleaseCardInfo( LPCARDDATAS carddatas );
```

With the function QAPIExtReleaseCardInfo it is possible with QAPIExtGetCardInfo to get out the asked card information

8 Annex



8.1 Frequently asked questions (FAQ)

8.1.1 General informations

Can I have any problems with network boards, sound cards, system components or other expansion boards?

Yes, according to how you have set the I/O address of your QUANCOM and the other component. You may encounter a resource conflict if the QUANCOM board and another component are using the same I/O address. Either change the I/O address of the QUANCOM board or the I/O address of the other component.

What is the purpose of the PCIInfo program ?

The program PCIINFO dumps the I/O addresses of all QUANCOM PCI-cards used in the system.

What is the program PCSETIO for?

The program PCSETIO allows the manual change of the base I/O address of a QUANCOM PCI-card.

What is the program PCGETIO for?

The program PCGETIO reads the base IO address from the PNP-Bios for the QUANCOM PCI board.

8.1.2 What kind of problems may occur if the board is running under DOS

Can I use the card with a memory manager? (QEMM 386,EMM386)

Yes, but the use of a memory manager can make your computer or the software running slower.

PCIINFO does not correctly identify the PCI-card, is that right?

The message "PCI-card unknown" shows that the device is no QUANCOM board. PCIINFO has been developed only for QUANCOM boards. Other components are listed as "unknown" (i.e. graphic cards, disk controllers, PCI bridges or other components).

8.1.3 Problems with boards running under Windows 98/95 and Windows XP/2000/NT

Why is the "Control Panel" board configuration dialog "QLIB" empty?

- There is no QUANCOM board in the system.

After installation I get the message "QLIBDRV.SYS not found" or "QLIBDRV.VXD not found" . What can I do?

- Check that the QLIB is installed properly. For further information about the installation process and the general programming with the QLIB please see the „QLIB“ manual which is included on the installation CD.

What is the program PCISSETIO for?

The program PCISSETIO allows the manual change of the base I/O address of a QUANCOM PCI-card.

What is the program PCIGETIO for?

The program PCIGETIO reads the base IO address from the PNP-Bios for the QUANCOM PCI board.

Why do I get the message "Driver QLIBNDRV.SYS" or "Driver QLIBNDRV.VXD" could not be load?

- Check that the QLIB is installed properly. For further information about the installation process and the general programming with the QLIB please see the „QLIB“ manual which is included on the installation CD.
- The driver for the QUANCOM board was not loaded. (Control Panel => System)

Windows XP/2000/NT: Must the QLIB be installed with Administrator-right?

- Yes, always install the QLIB with administration rights.

Windows XP/2000/NT: Why do I get the message "Driver could not be installed" during the installation?

- Installation was made without administration rights.

Windows XP/2000/NT: Why do I get the message "Driver QLIBNDRV.SYS could not be loaded"?

- Installation of drivers has failed, because the QLIB was not installed with administration-rights.
- QLIB-Software was installed on a network drive. Always install the QLIB on your local drive.

Windows XP/2000/NT: How can I install the driver QLIBNDRV.SYS manually?

If the QLIBNDRV.SYS failed to install it may be necessary to install the driver manually.

Please take the following steps to manually install the driver:

- Search on the installation CD in the directory "Tools" for the tool **instdrv.exe**. With this tool you can install and de-install the driver manually.
- Please call this tool with the following command line parameters:

instdrv qlibndrv d:\directory\qlibndrv.sys .

Replace **d:\directory** with the drive and the file, where the driver qlibndrv.sys is located.

- Go to “Start -> Settings ->Control panel ->(Administrative Tools / Windows 2000 only) -> Drivers” change the start type to “automatic”, then click on the “start” button. For the changes to become active please restart the system.

Why must I restart the driver after every reboot of the computer?

The starting type of the driver is set to “Manual”. If you want you can change this setting on „Automatic“ to start the driver on every reboot of the system.

8.2 Customer Communication and Help



You need help?

If you don't know how to go on during the installation or operation of your QUANCOM board please first consult this user's guide.

! Tip !

In the chapter „Frequently asked question“ a lot of answers to questions for known problems. They may help you to solve the problems. On the QUANCOM installation CD you can find a ASCII – Text – file README.TXT, which include changes made after printing of this user's manual.

! Important !

If you have further questions please contact our support team. For this case please prepare the following information:

- Exact type of the board.
- Version of the driver
- Version of the QLIB
- Operating system, Hardware equipment and Bus - System
- Name and Version of the program, which reports the failure
- A detailed failure description. To make sure, please try to reproduce the failure, and describe exactly, which steps led to this failure.

Who can you contact?

The QUANCOM internet website
<http://www.quancom.de/>

Per Fax
+49 22 36 / 89 92 - 49

Per E-Mail:
support@quancom.de

Address:
**QUANCOM INFORMATIONSSYSTEME
GmbH
In der Flecht 14
50389 Wesseling**

If you need urgent help call:

QUANCOM Hotline Germany
0 22 36 / 89 92 - 20

Monday-Thursday
from 9:00 to 18:00
Friday
from 9:00 to 17:00

Actual drivers

You can find the newest Version of QUANCOM software on our internet website <http://www.quancom.de>. You can also find a lot of information and „Frequently asked questions (FAQ's)“. Before you contact the QUANCOM support, please check if you are using the newest software version of the QUANCOM software.

Repair

If you are not sure whether your QUANCOM board is defective please call the QUANCOM Hotline:

Tel.: **+49 22 36 / 89 92 – 20**

Before you send us the QUANCOM board to be repaired call:

Tel.: **+49 22 36 / 89 92 – 20**

If you send us your QUANCOM board, please use original package or any other suitable package, to protect the contents against transport damage. You also need to send us a copy of the original bill and the RMA number.

You can shorten the repair time by sending us an exact failure description, so that a faster failure search is possible. Send your QUANCOM board directly to the service department of QUANCOM Informationssysteme GmbH.

8.3 Technical support form

If you have internet access please enter the following URL in your browser:
<http://www.quancom.de/quancom/qshop.nsf/techniksupport?OpenForm&eng> else photocopy this form and use the copy of this form as a reference for your current configuration. Complete this form before contacting QUANCOM Informationssysteme GmbH for technical support help and our applications engineers may answer your questions more efficiently. If you are using any other QUANCOM hardware or software products please add them to this configuration form. Include additional pages if necessary.

Name _____

Company _____

Address _____

Phone _____

Fax _____

Computer brand / Processor: _____

Operating system _____

Display adapter _____

Mouse _____

QUANCOM board _____

Other adapters installed _____

Hard disk (capacity, free) _____

The problem is _____

List any error messages _____

The following steps will reproduce the problem

8.4 Hardware and software configuration form

This form allows you to record the settings of your hardware and software. Complete this form each time you revise your software or hardware configuration, and use this form as a reference for your current configuration. Completing this form accurately before contacting QUANCOM Informationssysteme GmbH for technical support helps our applications engineers answer your questions more efficiently.

• QUANCOM Product

Name / Name of board: _____

Interrupt Level: _____

DMA Channel: _____

Base I/O Address: _____

Operating system: _____

• Other information

Computer brand and Model: _____

Processor: _____

Clock Frequency: _____

Type of Video Board Installed: _____

DOS Version: _____

Programming Language: _____

Programming Language Version: _____

• Other Boards in System

Base I/O Address of other Boards: _____

DMA Channels of other Boards: _____

Interrupt Level of other Boards: _____

8.5 Documentation comment form

QUANCOM Informationssysteme GmbH would like you to comment on the documentation supplied with our products. This information helps us to provide you with quality products to meet your needs. Include additional pages if necessary.

Title: **PROTO 2**

Edition date: **10.08.04 16:40**

Name: _____

Company: _____

Address: _____

Phone: _____

Fax: _____

Comment: _____

Mail to: support@quancom.de

Fax to: +49 2236 89 92 49

Address: **QUANCOM Informationssysteme GmbH
In der Flecht 14,
50389 Wesseling**

Germany

registered trade-mark:

Windows/386 is trade-mark of Microsoft
XT and PS/2 are trade-marks and IBM, OS/2 and AT are registered of the International Business Machines Corporation.

National Instruments, LabVIEW are registered trade-mark of National Instruments Corporation
MS, MS-DOS, Microsoft, Visual Basic, Windows, Windows NT are registered trade-mark of Microsoft Corporation

On other product- and company names, that are mentioned in this manual, it could bargain for marks of the respective owner.